



office  
design  
& contract  
Italy

DHOW +





# DHOW +

Lucci / Orlandini design

Il Dhow è una imbarcazione con vele triangolari che nell'antichità permetteva

il commercio fra oriente ed occidente.

Un nome, quindi, che ci riporta alla mente immagini classiche, le stesse immagini che hanno ispirato il concept del sistema.

Il punto focale del progetto sta infatti nel capitello di unione fra gamba e piano, un elemento in fusione di alluminio con funzione di giunto strutturale e di arricchimento estetico, perfetta sintesi di plasticità materica e leggerezza formale.

Il design arcuato del capitello è studiato in modo tale da non creare interruzioni fra le linee verticali della gamba e quelle orizzontali del sottopiano, la risultante è una silhouette pura e cristallina, sinuosa nelle curve e quasi tagliente negli spigoli, aggraziata nelle proporzioni e monolitica nella sua continuità. Le finiture disponibili, noce ed ebano, ben riflettono il prestigio di questa serie.

In ancient times, the word Dhow indicated a vessel with triangular sails used for trading between East and West. The word therefore recalls classical images, the same images that have inspired the concept for this system.

The focal point of this project is in the capital which joins the leg to the surface, a cast aluminum element whose function is both structural and aesthetic, a perfect synthesis of material plasticity and formal levity.

The arched capital is designed so as not to create interruption between the vertical line of the leg and the horizontal line of the lower plane. The result is a pure and clean silhouette, sinuous in its curves and almost cutting in its corners, graceful in proportions and at the same time monolithic in its continuity. The available wood finishings, Walnut and Ebony, well reflect the prestige of this series.

Dans le passé le mot Dhow indiquait un vaisseau avec des voiles triangulaires employé pour le commerce entre l'Orient et l'Occident.

Le mot donc rappelle images classiques, les mêmes images qui ont suggérées le concept du système.

Le point central de ce projet est dans le chapiteau qui relie le pied et le plateau, un élément de fusion en aluminium dont fonction est soit structurelle soit esthétique, une parfaite synthèse de plasticité matérielle et légèreté formelle.

Le chapiteau arcué est projeté afin de ne pas créer des interruptions entre les lignes verticales du pied et les lignes horizontales du sous-plan. Le résultat est une silhouette pure et cristalline, sinueuse dans les courbes et presque tranchante dans les angles, élégante dans les proportions et monolithique dans sa continuité. Les finitions disponibles, Noyer et Ebène, bien reflètent le prestige de cette gamme.



Il concetto di matrice classica del capitello trova la sua controparte nei piani in noce o ebano dal disegno asimmetrico e più libero. In essi si alternano linee curve e tagli secchi che conferiscono alla scrivania una caratteristica forma a "sciabola". L'allungo a goccia è un cerchio perfetto di cristallo che va ad incastrarsi in oggetto sotto al piano principale con il solo sostegno di una saetta in alluminio lucido, creando un'architettura moderna e quasi decostruita. Questo particolare utilizzo dei diversi elementi e dei materiali contribuisce ad accentuare la dinamicità delle composizioni possibili e a rendere ottimale lo sfruttamento degli spazi da parte dell'utilizzatore e dei visitatori.

The counterpart to the classical concept inspiring the capital, is found in the asymmetric design of the walnut and ebony surfaces. The design alternates curved lines and drastic cuts, resulting in its characteristic "sabre" shaped desk. The tear shaped extension is a perfectly round crystal surface which is fixed under the main plane and supported by an arch in polished aluminium, creating a modern and almost deconstructed architecture. This particular combination of the various elements and materials contributes to emphasize the dynamics of the possible compositions, allowing best use of available space both for hosts and guests

L'idée d'origine classique du chapiteau se révèle dans le design asymétrique des plateaux noyer et ébène. Le design alterne lignes courbées et coupes secs qui donnent au bureau une forme de "sabre". Le retour à goutte est un cercle parfait en verre qui est fixé sous le plateau principal et supporté par un arc en aluminium poli, en créant une architecture moderne et presque déstructurée. Cette particulière combinaison de différents éléments et matériels contribue à accentuer le dynamisme des compositions possibles et à rendre optimale l'utilisation des espaces soit pour l'utilisateur soit pour les visiteurs.







Dhow è un sistema che esprime al meglio il pregio classico delle forme e dei materiali impiegati (alluminio lucidato o spazzolato, essenze nobili di ebano e noce, cristallo temperato, cuoio naturale negli accessori) attualizzandolo con accessori e soluzioni compositive di stampo moderno.

Dhow is a system which combines in an admirable way the classical quality of shapes and materials used (polished aluminium, precious woods such as ebony and walnut, tempered glass, natural leather for accessories), with a modern conception in the design of accessories and compositions.

Dhow est un système qui combine au meilleur la qualité classique des formes et des matériels utilisés (aluminium poli, bois précieux comme ébène et noyer, verre trempé, cuir naturel pour accessoires) avec une nouvelle conception dans le design des accessoires et compositions.







La serie Dhow si arricchisce di una nuova variante in cristallo che ne esalta tutte le sue caratteristiche. Disponibile nella versione trasparente, satinato o anche retro-verniciato nero, la nuova veste è ulteriormente arricchita da una serie di mobili contenitori ad hoc laccati in nero.  
L'eleganza della struttura è enfatizzata dalla trasparenza e purezza del cristallo.

A glass top version has been added to the DHOW series enhancing all its elegant characteristics. It is available in various versions: transparent, satin finish or back-varnished black. A series of black lacquered matching cabinets is also available.  
The elegance of its structure is further enhanced by the transparency and pureness of the glass.

La gamme Dhow s'enrichit d'une nouvelle version en verre qui en exalte toutes les caractéristiques. Disponible dans la version transparent, satiné ou laqué noir, la nouvelle apparence est encore enrichie par une série de meubles à compartiment ad hoc laqués noir.  
L'élégance de la structure est accentuée de la transparence et pureté du verre.





Dhow, una serie raffinata che si rispecchia anche nei contenitori dedicati: le consolle-etageres e gli armadi a colonna poggiano sulla caratteristica pedana in alluminio e sono rifiniti con top in cuoio o in legno, completati da un sistema di illuminazione che ne esalta le caratteristiche. Completano la varietà di contenitori le infinite soluzioni di armadi, disponibili nella gamma "Librerie Universali".

Dhow is an extremely elegant series, including its storage units: the consoles-etageres and the column cabinets stand on the characteristic aluminium base, their surfaces are finished in leather or wood, and include a lighting system which exalts their beauty. The series may be completed by the infinite solutions possible with the cabinets available in the series "Librerie Universali".

Dhow est une gamme raffinée qui se reflète aussi dans les meubles de rangement: les console-étagères et les armoires colonne reposent sur la caractéristique base en aluminium parfaits avec top en cuir ou en bois, et complétés par un système d'éclairage qui exalte leur beauté. La gamme peut être complétée par les nombreuses solutions d'armoires disponibles dans la gamme "Librerie Universali".







Nonostante la leggerezza della sua linea,  
Dhow riesce ad offrire un'ottima privacy.  
Le ampie paratie, disponibili sia in  
essenza che in cuoio, ed i fianchi  
pannellati laterali, si abbinano  
perfettamente creando un piacevole  
contrasto con la struttura in  
alluminio spazzolato.

Notwithstanding the lightness of its design,  
Dhow provides very good privacy.  
The ample modesty panels, available either in  
wood or leather, and the side panels, create a  
pleasant contrast with the aluminium structure.

Malgré la légèreté de sa gamme,  
Dhow offre la meilleure intimité possible.  
Les amples voiles de fond, disponibles soit  
en bois soit en cuir, et les pieds panneaux,  
créent un plaisant contraste avec la structure  
en aluminium.







La versione in cristallo nero si esprime al meglio con i dettagli della paratia in cuoio rifinita a mano ed i mobili contenitori laccati in abbinamento. La struttura in alluminio verniciato esprime nel contempo solidità ed eleganza esaltatandone il design.

The black varnished glass version is at its best when combined with hand finished leather modesty panel and matching lacquered cabinets. The varnished aluminum structure conveys both solidity and elegance, and enhances its design.

La version en verre s'exprime au mieux avec les détails du voile de fond en cuir perfectionné à la main et les meubles compartiment laqués à coordonner. La structure en aluminium laqué exprime, en même temps, solidité et élégance en valorisant le design.





Le ampie superfici dei tavoli riunione creano ambienti dinamici e moderni permettendo lo svolgimento di un lavoro sia individuale che di equipe. La geometria della struttura, dall'originale ed ergonomico disegno, consente un utilizzo ottimale senza negare la purezza ed il rigore delle sue linee e forme.

The large surfaces of meeting tables create a dynamic and modern habitat which allows both individual or team work. Their geometric structure, is ergonomically designed to provide optimum use, maintaining the purity and rigor of the design.

Les amples surfaces des tables réunion créent des milieux dynamiques et modernes en permettant le déroulement d'un travail soit individuel soit d'équipe. La géométrie de la structure est ergonomiquement projetée pour fournir une utilisation optimale préservant la pureté et rigueur du design.





## Scrivanie in legno

Desks in wood

Bureaux en bois

## Accessori per scrivanie in legno

Accessories for desks in wood

Bureaux en bois accessoires

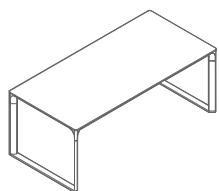

DW190  
L 190 | P 90 | H 73

**Scrivania**  
Desk  
Bureau

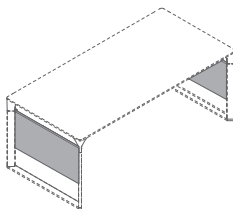

DWF  
P 90  
P 102  
P 90/102

**Coppia fianchi pannellati in legno**  
Wooden full side panels  
Pieds panneaux en bois

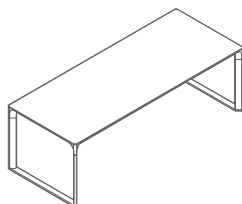

DW210  
L 210 | P 102 | H 73

**Scrivania**  
Desk  
Bureau

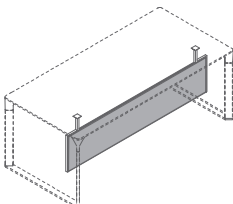

DWPL / DWPC  
L 190  
L 210

**Paratie in legno o cuoio**  
Modesty panels wood or leather  
Voiles de fond bois or cuir

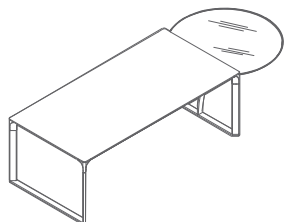

DW290T  
L 290 | P 110 | H 73

**Scrivania con allungo a goccia**  
Desk with drop-shaped extension  
Bureau avec retour convivialité

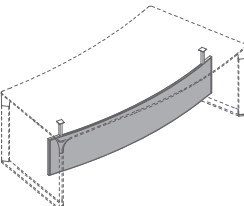

DWPAC  
L 215

**Paratia arcuata in cuoio**  
Arch-shaped modesty panel covered in leather  
Voile de fond arquée en cuir

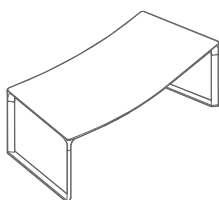

DW215A  
L 215 | P 108 | H 73

**Scrivania arcuata**  
Arch-shaped desk  
Bureau arqué

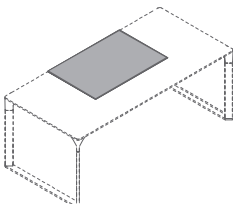

DWSMC  
L 90 | P 60

**Sottomano in cuoio**  
Leather inlay  
Sous-main en cuir

DX

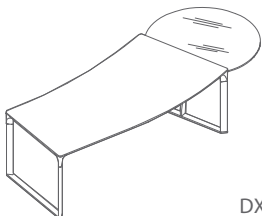

DW290AT  
L 290 | P 118 | H 73

**Scrivania arcuata con allungo a goccia**  
Arch-shaped desk with drop shaped extension  
Bureau arqué avec retour convivialité

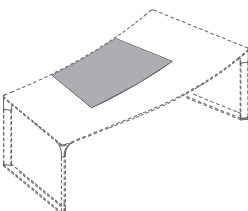

DWSMAC  
L 100 | P 62

**Sottomano arcuato in cuoio**  
Arch-shaped leather inlay  
Sous-main arqué en cuir

DX

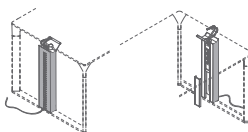

DWEL

**Elettrificazione scrivania**  
Desk wire management  
Passage cable pour bureau





## Scrivanie in cristallo

Desks in glass

Bureaux en verre

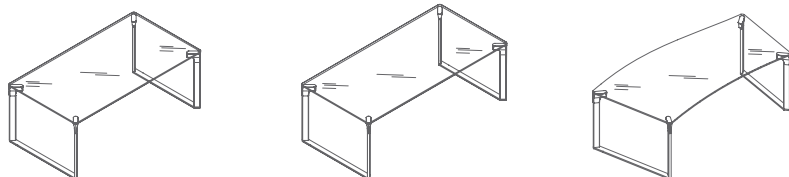

DW190 CR CS NE

DW210 CR CS NE

L 190 | P 90 | H 73

L 210 | P 102 | H 73

**Scrivanie in cristallo**

Glass desks

Bureaux en verre

DW215 CR CS NE

L 215 | P 108 | H 73

**Scrivania arcuata in cristallo**

Arch-shaped glass desk

Bureau arqué en verre

DW319 CR CS NE

DW321 CR CS NE

L 216 | P 208 | H 73

L 238 | P 208 | H 73

**Scrivanie in cristallo**

**con allungo portante 3 cassetti**

Glass desks

Bureaux en verre

DW322 CR CS NE

L 230 | P 215 | H 73

**Scrivania arcuata in cristallo**

**con allungo portante 3 cassetti**

Glass desk

Bureaux en verre

DW219 CR CS NE

DW221 CR CS NE

L 216 | P 208 | H 73

L 238 | P 208 | H 73

**Scrivanie in cristallo**

**con allungo portante 2 cassetti**

Glass desks

Bureaux en verre

DW222 CR CS NE

L 230 | P 215 | H 73

**Scrivania arcuata in cristallo**

**con allungo portante 2 cassetti**

Bureaux en verre

Glass desk

## Elementi di completamento per scrivanie in cristallo

Complementary elements for desks in glass

Éléments complémentaires per bureaux en crystal

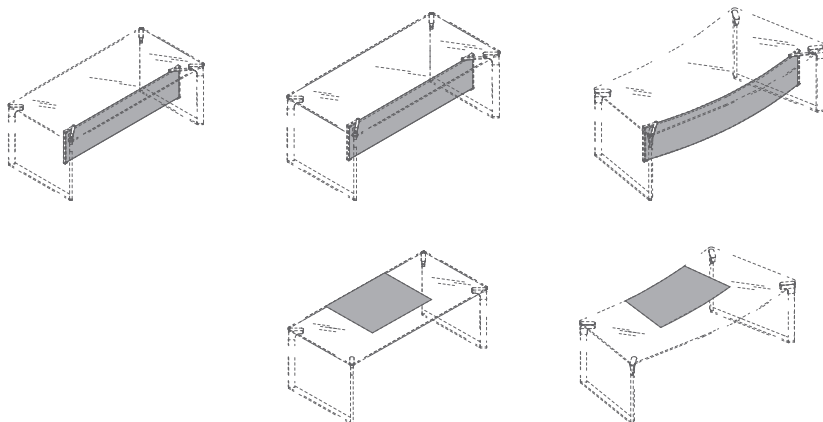

DWPC19CR

DWPC21CR

DWPACCR

L 190 / L 210 / L 215

**Paratie per scrivanie in cristallo**

Modesty panels for glass desks

Voiles de fond pour bureaux en

verre

DWSMC

DWSMAC

L 90 | P 60

L 100 | P 62

**Sottomano in cuoio**

Leather inlay

Sous-main en cuir

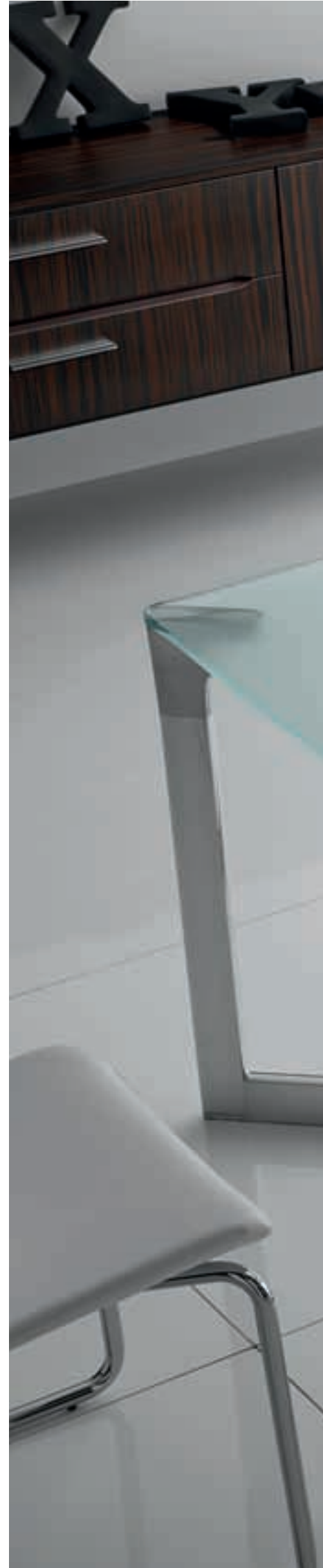





## Elementi di complemento per scrivanie in legno

Complementary elements for desks in wood  
Éléments complémentaires pour bureaux en bois

## Elementi di complemento per scrivanie in cristallo

Complementary elements for desks in glass  
Éléments complémentaires pour bureaux en crystal

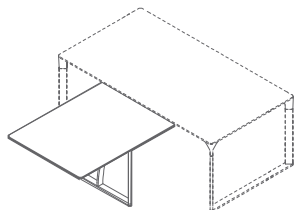

DWTA  
L 100 (120) | P 80 | H 68

**Tavolo appoggio per scrivania**  
Briefing table for desk  
Table convivialité pour bureau

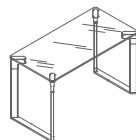

DWTD CR CS NE  
L 100 | P 060 | H 73

**Allungo indipendente in cristallo**  
Transparent glass independent return  
Retour indépendant en verre opale

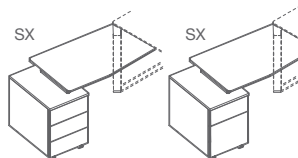

DWAL2 / DWAL3  
L 115 | P 65 | H 68

**Allungo con cassettiera portante**  
Return with load bearing pedestal  
Retour avec caisson porteur



DWCR3C / DWCR2C  
L 42,5 | P 60 | H 58

**Cassettiera su ruote in legno top cuoio**  
Wooden pedestal on castors leather top  
Caisson en bois à patins top en cuir

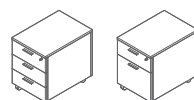

DWCR3 DWCR2  
L 42,5 | P 60 | H 58

**Cassettiera su ruote**  
Mobile pedestals  
Coffres mobiles

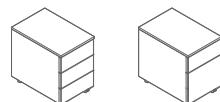

DWCR3 / DWCR2  
L 42,5 | P 60 | H 58

**Cassettiera su ruote in legno**  
Wooden pedestal on castors  
Caisson en bois à patins

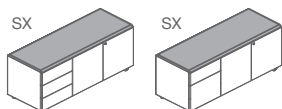

DWCS3C / DWCS2C  
L 120 | P 45 | H 58

**Mobile di servizio su ruote in legno, 2-3 cassetti, 2 ante, top cuoio**  
Wooden storage unit  
2-3 drawers 2 doors leather top  
Meuble de service en bois à patins  
2-3 tiroirs 2 portes battantes, top en cuir

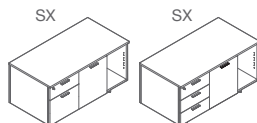

DWCS3 DWCS2  
DWCS3F DWCS2F  
L 120 | P 060 | H 58  
L 120 | P 060 | H 58

**Mobile di servizio su ruote 2-3 cassetti, 1 anta e porta PC**  
Mobile storage unit 2-3 drawers, 1 door and PC holder  
Meuble de service sur roulettes  
2-3 tiroirs, 1 porte et porte PC

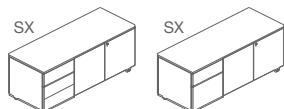

DWCS3 / DWCS2  
L 120 | P 45 | H 58

**Mobile di servizio su ruote in legno, 2-3 cassetti, 2 ante**  
Wooden storage unit, 2-3 drawers, 2 doors  
Meuble de service en bois à patins, 2-3 tiroirs, 2 portes battantes

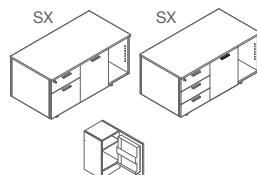

DWCS3F DWCS2F  
L 120 | P 060 | H 58

**Mobile di servizio su ruote predisposto per frigo 2-3 cassetti, 1 anta e porta PC**  
Mobile storage unit arranged for fridge 2-3 drawers, 1 door and PC holder  
Meuble de service sur roulettes disposé pour réfrigérateur 2-3 tiroirs, 1 porte et porte PC







**Librerie universali**  
Universal bookshelf  
Bibliothèque universelles

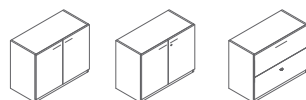

M2 / M3 / M2F  
L 90 | P 45 | H 72

**Libreria bassa h.72**  
Low cupboard  
Meuble bas

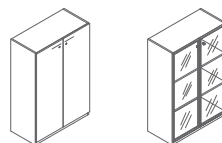

M12 / M13K  
L 90 | P 45 | H 138

**Armadi h.138**  
Cupboards h.138  
Armoires h.138

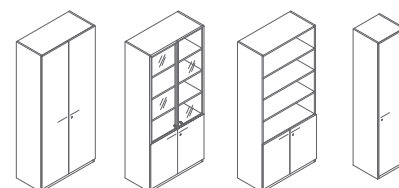

M22 / M23K / M23G / M25 / M25P  
L 90 | P 45 | H 200

**Armadi h.200**  
Cupboards h.200  
Armoires h.200



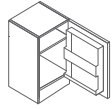

**A3080**  
25 Lt.

**Frigo**  
Refrigerator  
Réfrigérateur

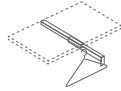

**PEN**

**Appendiabiti**  
Coat hanger  
Penderie

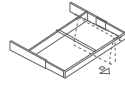

**TDS90**

**Telaio estraibile**  
Pull-out frame for suspended files  
Cadre extractible pour dossier

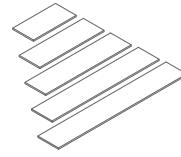

**D/TOP 90 135 180 225 270**

L 90  
L 135  
L 180  
L 225  
L 270

**Top a bordo dritto cm S 1,9 P 45**  
Tops with straight edges  
Tops de finition bord droit épaisseur

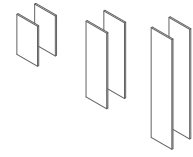

**D/F 07 13 20**

H 73  
H 138  
H 200

**Fianchi laterali a bordo dritto cm S 2**  
Finishing lateral sides with straight edge  
Finitions latérales bord droit



## Tavoli riunione in legno

Meeting tables in wood  
Tables réunion en bois

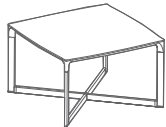

DWTQ12  
L 120 | P 120 | H 73

**Tavolo riunione quadrato**  
Square meeting table  
Table réunion carrée

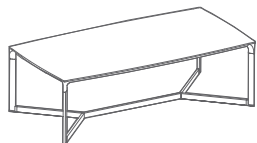

DWTC24  
L 240 | P 125 | H 73

**Tavolo riunione**  
Meeting table  
Table réunion

## Tavoli bassi in legno

Low tables in wood  
Tables basses en bois



DWTB60  
L 60 | P 60 | H 40

**Tavolo basso**  
Low table  
Table bas

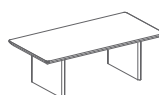

DWTB120  
L 120 | P 60 | H 40

**Tavolo basso**  
Low table  
Table bas

## Tavoli riunione in cristallo

Meeting tables in glass  
Tables réunion in crystal

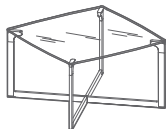

DWTQ12 CR CS NE  
L 120 | P 120 | H 73

**Tavolo consiglio quadrato in cristallo**  
Square meeting table in glass  
Table reunion carré en verre

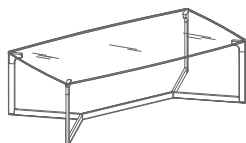

DWTC24 CR CS NE  
L 240 | P 125 | H 73

**Tavolo consiglio in cristallo**  
Glass meeting table  
Table reunion en verre

## Tavoli bassi in cristallo

Low tables in glass  
Tables basses in crystal



DWTB60 CR CS NE  
L 60 | P 60 | H 40

**Tavolo basso in cristallo**  
Low table with glass top  
Table basse avec plateau en verre

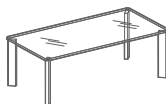

DWTB120 CR CS NE  
L 120 | P 60 | H 40

**Tavolo basso in cristallo**  
Low table with glass top  
Table basse avec plateau en verre







Contenitori dedicati  
Storage units  
Éléments de rangement

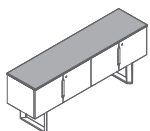

DWEC180C  
L 180 | P 45 | H 73

**Etagere consolle 4 ante top cuoio**

Etagere consolle 4 doors  
leather top  
Etagère consolle 4 portes  
battantes, top en cuir

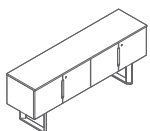

DWEC180  
L 270 | P 45 | H 73

**Etagere consolle 4 ante**

Etagere consolle  
4 doors  
Etagère consolle  
4 portes battantes

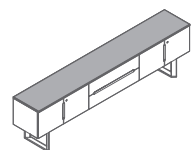

DWEC270C  
L 180 | P 45 | H 73

**Etagere consolle 4 ante 2 cassetti top cuoio**

Etagere consolle  
4 doors 2 drawers  
Etagère consolle  
4 portes battantes 2 tiroirs

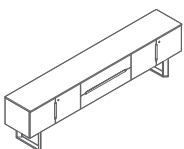

DWEC270  
L 270 | P 45 | H 73

**Etagere consolle 4 ante 2 cassetti**

Etagere consolle  
4 doors 2 drawers  
Etagère consolle  
4 portes battantes 2 tiroirs

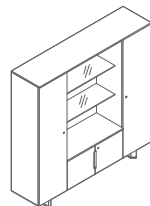

DWAR18 / DWAR18I  
L 180 | P 45 | H 180

**Libreria con vano a giorno con o senza illuminazione**

Bookcase with open compartment  
with or without lighting system  
Bibliothèque à élément ouvert  
avec ou sans système d'éclairage

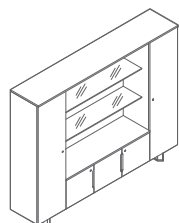

DWAR22 / DWAR22I  
L 225 | P 45 | H 180

**Libreria con vano a giorno con o senza illuminazione**

Bookcase with open compartment  
with or without lighting system  
Bibliothèque à élément ouvert  
avec ou sans système d'éclairage







**Finiture scrivanie e tavoli**  
Desks and tables finishings  
Éléments de rangement



**Finiture contenitori**  
Units finishings  
Éléments de rangement

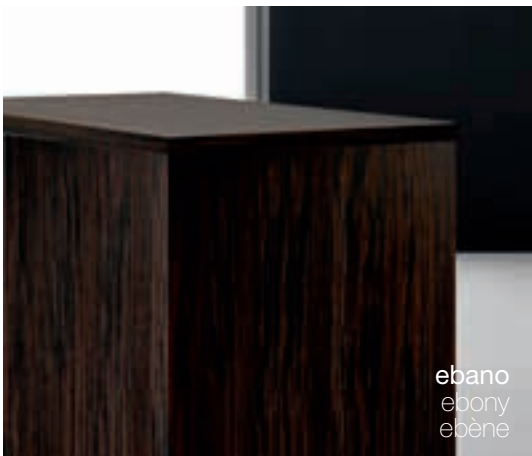

## Finiture

Finishings

Finitures

Le pregiate essenze di ebano e noce, verniciate ad acqua con finitura a poro aperto ed opacità accentuata, conferiscono naturalezza ed eleganza.

I materiali della struttura e degli accessori si legano con i legni in modo equilibrato ed armonico: il cuoio impunturato, gli elementi in pressofusione spazzolato lucido ed il cristallo trasparente esaltano ed enfatizzano la ricchezza delle essenze lignee.

Disponibili anche le versioni in cristallo trasparente, satinato e nero.

The use of precious woods such as ebony and walnut, water veneered to an opaque finish, result in natural elegance. The materials used for the structure and accessories mix with the woods in a balanced and harmonious way: the stitched leather, the brush polished die cast elements and the transparent tempered glass, enhance the beauty and elegance of the wood elements. Also available in clear, satin or black glass.

Les précieux bois d'ébène et noyer, laqués à l'eau avec finition à pore ouvert et opacité prononcée, donnent naturel et élégance. Les matériels de la structure et des accessoires se mélangent avec les bois de façon équilibré et harmonique: le cuir maillé, les éléments en sous pression de l'aluminium poli, et le verre transparent vantent la richesse des éléments en bois. Disponibles aussi les versions en verre transparent, satiné et noir.



AD  
Alberto Sala

Photo  
Roberto Lughi, Fotogramma

Digital Color Management  
Fotogramma

Impaginazione  
Alessia Gasperi  
Giulia Pretti

Stampa  
Stampa Grafica Srl